

Specific installation instructions

F132-SCP

The mounting set is a wiring harness specially designed for these vehicles ⇒



Installation on the vehicle

Cut the needed length of wires of **COMDIS®** wiring harness and connect them (weld and insulate) to the vehicle as indicated (see below).

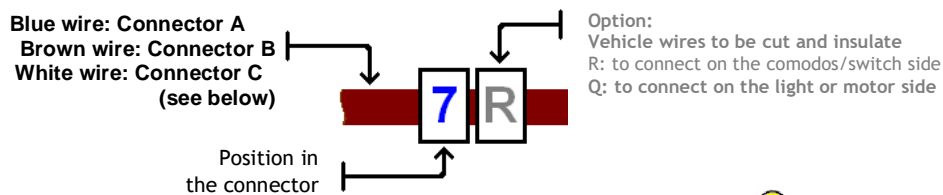

Examples:

- The wire **6** has to be connected to the pin 6 of the vehicle connector A.
- The wire **2 R** has to be connected to the way/pin 2 from the vehicle connector B - side "switches". The vehicle wire is cut and insulate

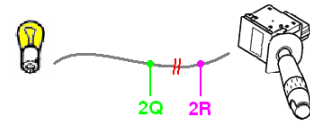
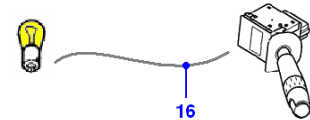

Vehicle connector

A Connector 10 pins

(Connector added to the left switches)

⇒ Plug the 10 pins connector from Sojadis specific harness to the original switch



B Connector 12 pins

(Connector added to the right switches)

⇒ Plug the 12 pins connector from Sojadis specific harness to the original switch



C Connector 14 pins

(Connector on the top column calculator)

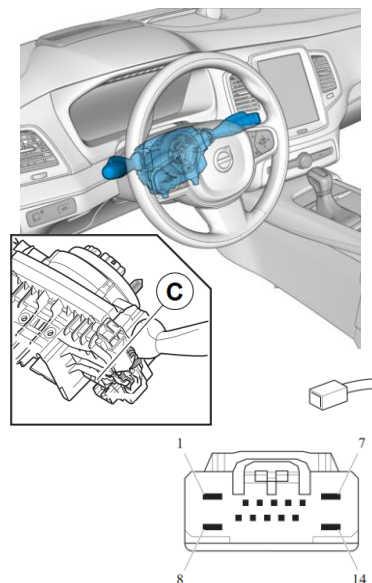

Other wires colours

Red ⇒ to connect to Ignition+ (12v after ignition)

Black ⇒ to connect to ground



Place du Maréchal LECLERC
F-49510 JALLAIS France
☎ 02 41 64 05 58 / 📠 02 41 64 08 56
e-mail : sojadis@sojadis.fr
web : www.sojadis.fr

